

RoHS compliant

Specification:

Material:
 Contact Material: Brass
 Contact plating: Au or Sn Over 50μ" Ni
 Insulator Material: Black Polyester UL94V-0
 Standard: LCP+30%G.F

Electrical:
 Current rating: 1Amps/contact max.
 Contact resistance: ≤20mΩ/contact
 Insulation resistance: ≥1000MΩ at V=100V
 Withstanding Voltage: 300V AC/minute

Mechanical:
 Mechanical life cycle: min.200
 Operating temperatures: Gold Plated: -55°C to +105°C
 Tin plated: -40°C to +105°C
 Soldering temperature: +245°C, 5s.

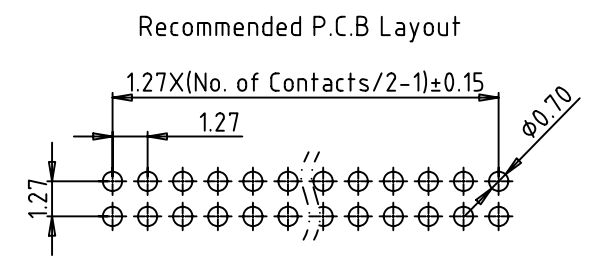
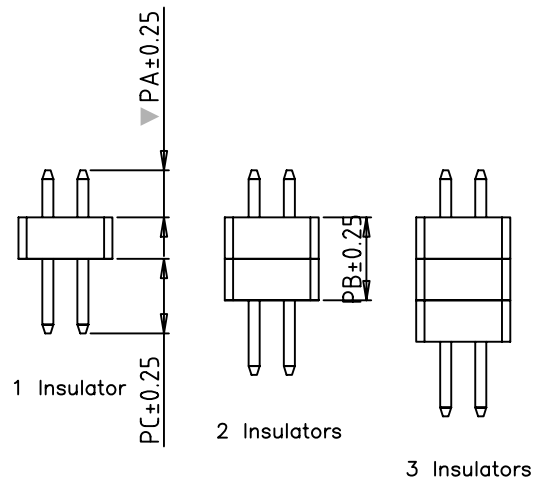
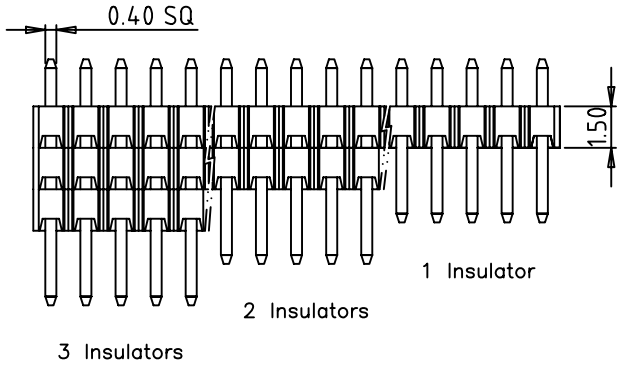
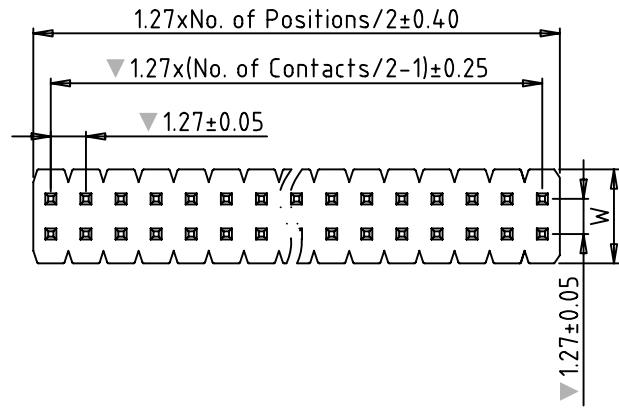

Ordering Information

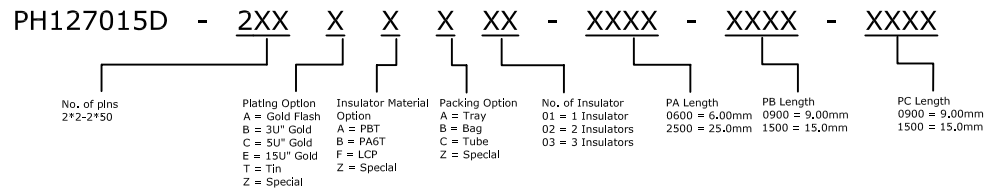

TM-LINK		TM-Link Technology Limited			
TITLE: 1.27mm Pin Header Dual row Dip type					
TOLERANCES UNLESS OTHERWISE SPECIFIED:	DRAWN	Robert	DATE:	2012-03-28	DRAWING NO.:
X.XX ±0.25	CHECKED	Jhon	PROJECTION		
X.X ±0.35	APPROVED	Jack	SIZE:	A4	
X. ±0.50			UNIT:	MM	SCALE: 1:1
					SHEET: 1/1
					REV: A